

TRIZ-Based Design of Rapid 3D Modelling Techniques with Formative Manufacturing Processes

César Cárdenas¹, Yuliana Rivera², Ricardo Sosa² and Oscar Olvera²

*¹The Distributed and Adaptive Systems Lab for Learning Technologies
Development/Mechatronic Department*

*²Innovation in Design and Manufacturing Research Chair
Tecnológico de Monterrey – Campus Querétaro
México*

1. Introduction

By accelerating the new product development process, manufacturers remain competitive (Zailani et al. 2007). Physical modelling helps in this decision making process by allowing real visualization of information about the thing the model represents (Kupka 2010). Two particular three-dimensional techniques are used in physical modelling, mock-up and prototyping. A mock-up is a scale or real-size model of a design or device, used to teach, demonstrate, evaluate, and promote among other purposes. A prototype is a physical model with the most important system functionalities implemented on it. Therefore, a prototype may be used as proof of concept for the new product. A mock-up is less expensive since it requires less material and less time to be built. Most of the mock-up techniques remain free handwork based. Some of the materials used for mock-up are clay, paper, wood, plastic, and metal. A mock-up is considered a prototype if it provides some functionality of a system and allows the test of a design. Several rapid prototyping techniques have been proposed to accelerate the new product development process (Chua et al. 2010). Rapid prototyping is defined as the automatic construction of physical objects using additive manufacturing technology. Rapid prototyping is also known as solid freeform fabrication, rapid manufacturing, layered manufacturing, additive fabrication, additive manufacturing or rapid manufacturing. Because the quality of the final product obtained by rapid prototyping, it has extended its original intend to discrete manufacturing and fine-art applications. The traditional process includes a computer-aided design stage that convert the three-dimensional object into two-dimensional layers, then the rapid prototyping machine builds the three-dimensional object by depositing each two-dimensional layer by means of depositing liquid, powder, or sheet material which are joined together to produce the final version of the three-dimensional object. The main advantage of additive manufacturing is the ability to create almost any shape or geometric feature (Chua et al. 2010). Most of the rapid prototyping techniques have been automated. Because most of the rapid prototyping techniques built a mock-up instead of a real prototype, we think the term has been misused. Strictly speaking, rapid mock-up should be used instead of rapid prototyping. If the new concept is in the first stages of design (i.e. the ideation stage), a

designer may use a mock-up to refine the solution proposal; once the solution has been chosen, a prototype can be built to present the definite solution before manufacturing. Besides the two three-dimensional physical modelling techniques presented above, sketching is also used during the first's stages of the design process to accelerate the new product development process. Sketching is the means that architects, designers, artists and sculptors use to represent, visualize and study their concepts of three-dimensional objects. Traditionally, sketching has been done with pencils and paper, resulting in a set of two-dimensional drawings representing three-dimensional objects. The current process of design is, usually, a sequence of two-dimensional hand sketching, two-dimensional computer drafting, three-dimensional computer modelling, and finally, rendering (Hopkinson et al. 2006). In recent years, three-dimensional sketching has gained popularity as an efficient alternative to conventional three-dimensional geometric modelling for rapid prototyping; as it allows the user to intuitively generate a large range of different shapes. In this chapter, we propose a new rapid three-dimensional physical modelling technique based on the wire bending structure approach that goes beyond three-dimensional modelling and before the rendering process. Designers might need a physical model before rendering in order to refine their concept. This new rapid physical modelling manufacturing process builds a three-dimensional sketch of the concept. Since this manufacturing process is added in the early stages of design we have called it rapid three-dimensional wireframing manufacturing process or rapid three-dimensional wireframing for short (rapid 3D wireframing). As we said before, this new rapid mock-up technique is based on wire bending structures. Furthermore, to design a machine that automates this new rapid 3D wireframing manufacturing process we propose a methodology supported by TRIZ principles. TRIZ is also known as the theory of inventive problem solving and is very well known in the industry worldwide (Orloff 2010). To validate this methodology we carried out several design process experiments. First we carried out experiments on wire bending freeform fabrication, and then we performed experiments using the proposed methodology and compared results with the first experiments. Both experiments were executed by mechanical designers of sophomore and senior levels at one university. A third experiment was executed and consisted on designing machines that automate the rapid mock-up technique. We present relevant statistics and results found in these experiments. Furthermore, we dedicate a section to explain our advancements in the construction of the first prototype of our rapid three-dimensional sketching machine. Finally, we provide conclusions and future work.

2. Engineering design thinking and rapid prototyping

Engineering design is the process that engineers follow to device a new product or system. In its traditional form, it is a sequential set of activities (Pahl et al. 2007). The activities are the following: identify the need or the problem, research about the need or the problem, develop possible solution(s), select the best possible solution(s), construct a prototype, test and evaluate the solution(s), communicate the solution(s). A first generation of the product or system is finished when all the steps are completed or when a first cycle is finished. Next generations of the product or system will follow after the first iteration in the engineering design cycle. Depending on the specialization, professionals practice every step differently. There are a plenty of techniques for each step and the more adequate is related to the product or system domain (Kamrani and Nasr 2010). In a widest form, the engineering design process is embedded in the Product Lifecycle Management (PLM) philosophy (Saaksvuori & Immonen

2010). In the PLM philosophy, the steps are: imagine, define, realize, service, and dispose. Motivated by sustainability efforts, the PLM cycle has been extended from the realize step to maintain and retire steps. This new PLM is also known as closed-loop PLM (Kiritsis 2010). A methodology that integrates both the engineering design process and the PLM philosophy has been recognized as a new engineering education paradigm (Crawley et al. 2010). Furthermore, the engineering design process can be matched to the project management cycle as well (Lessard 2007). In (Cárdenas 2011), we present a match between the engineering design process, the project management process, the service-learning process at Monterrey Tech and an integrated course we teach at our university focused on designing socially relevant system for social change. The process can also be found in (Cárdenas 2009). In Table 1, we present the match between the processes we mentioned above.

Framework	Stage 1	Stage 2	Stage 3	Stage 4
Engineering Design Process	Identifying the need or the problem + Research about the need or the problem	Develop possible solution(s) + Select the best possible solution(s)	Construct a prototype + Test and evaluate the solution(s)	Communicate the solution(s)
Product Lifecycle Management	Imagine	Define	Realize	Service + Dispose / Maintain + Retire
Project Management	Defining the project	Planning the project	Executing and controlling the project	Delivering the project
Integrated Course (Cárdenas 2009)	Social problem research	Concept generation + Concept pre-evaluation + Concept documentation	Concept development + Concept documentation	Concept presentation + Concept documentation
Service-Learning at Monterrey Tech (QEP)	Social problem formulation	Solution proposal	Planning and executing proposal	Assessment of social impact + Reflection from the experience + Ability to argue and use sources of information
INNOWIZ	Problem definition	Idea generation	Idea selection	Idea communication
TRIZ	Finding a problem	Abstractize the original problem to find the general contradiction	Use the general principles to solve the general problem	Concretize the general solution to the original problem

Table 1. Match between general engineering design frameworks.

Table 1 is presented to provide a systemic view of the engineering design thinking. Additionally, we add the INNOWIZ¹ design framework. The INNOWIZ framework synthesizes the design thinking (Plattner et al. 2010). INNOWIZ creators state that any stage of the general design process can be divided in the four stages (like a fractal). At the table, we also added the general TRIZ methodology (Orloff 2010). The fact that people has embedded the engineering design process in their thinking has been recognized as engineering design thinking (Dym et al. 2006).

Now based on stages 1 and 2 from Table 1, we present in Figure 1 the innovation funnel (Buxton 2007) for our integrated course (Cárdenas 2009). The innovation funnel shows that several techniques are used to decide the final concept (or solution). The innovation funnel is composed by several divergent and convergent phases. The reader can notice that Rapid Prototyping might also be used not only after the concept is finally selected to demonstrate or prove aspects of the design but also at different moments during the innovation funnel. In such sense Rapid Prototyping can be used to help defining the concept of the system (e.g. in terms of size and form).

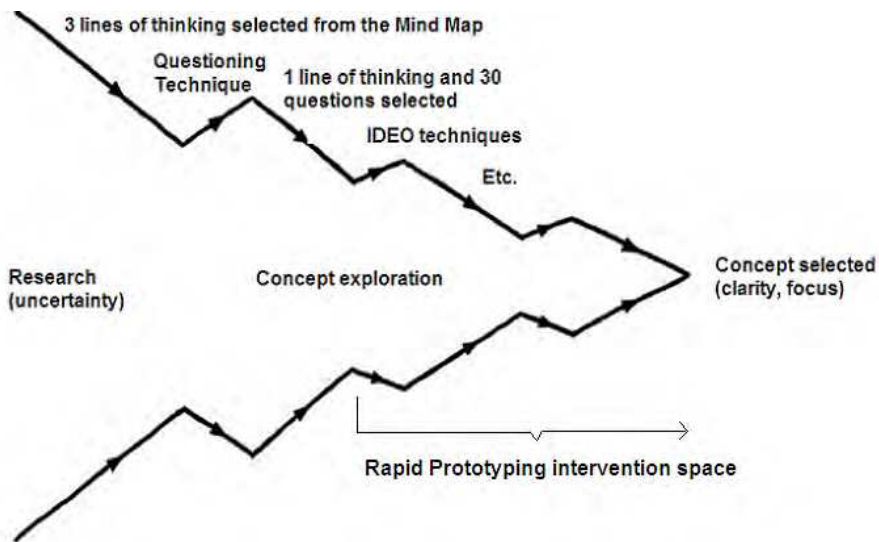

Fig. 1. Innovation funnel for our integrated course (Cárdenas 2011).

Rapid Prototyping has been traditionally used after the concept is defined and as a way to validate the concept. Several techniques for rapid prototyping have been developed (Chua et al. 2010), and most of them are based on the layered principle. Because of that, the term additive manufacturing has been recently adopted to describe rapid prototyping techniques (Gibson et al. 2009). The application of Rapid Prototyping in early stages of the design process has been previously proposed (Simondetti 1998). The time extent for applying Rapid Prototyping in the innovation funnel as indicated in Figure 1 is known as the conceptual design phase (Bruno et al. 2003).

¹ <http://www.innowiz.be/>

There are several ways to accelerate the new product development process. Concurrent engineering (Cha et al. 2003), Time to Market (TTM) (Smith and Reinertsen 1998), and Rapid Prototyping (Kamrani and Nasr 2010). In our previous work (Cárdenas 2009), we used the concurrent engineering approach up to the concept is defined then for rapid prototyping we use an open source hardware platform named ArduinoTM.² For the mock-up part which comprises the conceptual design phase we are exploring new paradigms. In the following section we will explain this new paradigm

3. Formative processes and TRIZ principles for new rapid physical 3D modelling techniques

Frequently, the designer uses two-dimensional sketching and computer-aided for conceptual design (Buchal 2002) or physical modelling using the materials mentioned in section 1 (Schrage 1993). Hand-based techniques are used because their flexibility, adaptability, creativity generation, and cost (Jenkins and Martin 1993).

Traditional rapid prototyping techniques belong to additive manufacturing processes. Manufacturing processes are mainly based on subtractive manufacturing processes (Suh et al. 2010). In this chapter we exploit the less known and used family of formative manufacturing processes (Buswell 2007) to build a new rapid 3D physical modelling technique. Formative processes have been used mostly in art. There are many examples of this type of processes in sculpture³. They have been also used in jewels since thousands of years back. Formative manufacturing processes have the following advantages: they are environmental friendly and economic since the material can also be composed by wasted material. On the contrary, subtractive and additive manufacturing processes generate wasted material and in particular additive manufacturing processes are very expensive. Formative manufacturing processes use only the necessary material without almost any waste. The Origami technique (Demaine and O'Rourke 2007) is an example of formative manufacturing processes. Many wire bending based products are fabricated in mass. Some examples are jail birds, wire baskets, cookware tools, mice tramps, and hooks among many others.

The new rapid physical modelling technique we propose in this chapter is called Rapid Physical 3D Wireframing. The name comes from the final 3D object we want to achieve. A wire-frame model is a visual presentation of a three dimensional or physical object used in 3D computer graphics. In our case we intend to reproduce a physical 3D wireframe object. We do not want to call rapid physical 3D sketching, rapid 3D prototyping, and neither rapid physical mock-up. The reason is that the final product of this process is not a sketch, not a mock-up, and neither a prototype. There are a plenty of patents and commercial machines that blend wires but their use is not for the conceptual design phase.

TRIZ is a problem-solving approach developed from the patent mining experience of the Russian Genrich Altshuller and his colleagues. TRIZ in English means Theory of Inventive Problem Solving (TIPS) (Orloff 2010). Altshuller discovered that at least 80% of the patents were based on some general principles. Training people on such general principles gives them the possibility to invent solutions to problems in a structured form. The main TRIZ concept is contradiction. Technical contradictions emerge when two associated necessities from a product or problem are in conflict. The key issue in TRIZ methodology is to find the

² <http://www.arduino.cc>

³ <http://www.wirelady.com/>

main contradictions in the technological innovation. According to Altshuller, there are three categories of contradictions: technical, physical and human. The methodology proposed by Altshuller consists on a series of the following sequential steps: finding a problem, abstractize the original problem to find the general contradiction, use the general principles to solve the general problem, concretize the general solution to the original problem. In Table 1 we have included this general procedure as a general engineering design thinking methodology. The use of this methodology will be explained in the following section.

4. Research contributions and questions

The contributions of this chapter are the following. First, a new rapid 3D physical modelling technique is proposed, this technique is based on formative manufacturing processes. We named this technique Rapid 3D Wireframing. The technique is expected to be used in early conceptual design phases of the new product development process. Therefore, it modifies the industrial design process but this is not evaluated in this chapter. Second, a TRIZ-based design process is proposed to reduce the complexity of the mechatronic design to print the object (Rapid 3D Wireframing). We have named MDSU this design process. Since the Rapid 3D Wireframing technique is new, so the MDSU design process and the application of TRIZ principles to the design of this kind of mechatronic systems. MDSU stands for Mesh, Unfolding (*Desdoblado*), Separation and Union (MUSU in English). The MDSU approach reduces the degree of freedom necessary in mechatronic systems to automate the process. These four sub-processes belong to TRIZ principles. It is expected that the Rapid 3D Wireframing technique will be automatic; therefore a first prototype will be explained briefly. In this chapter the following research questions are explored: the implementation of MDSU will ease the design process of the mechatronic system; the implementation of MDSU improves the design thinking process and reduce the development time of the mechatronic system; the implementation of the Rapid 3D Wireframing technique improves the work conditions of the designers; the implementation of the Rapid 3D Wireframing technique reduces the designers competencies related to the conceptual design phase; the implementation of Rapid 3D Wireframing improves the new product design process. Through our experiments we will try to answer the previous research questions.

5. Experiments

Our main objective is to define a design process of mechatronic systems for Rapid 3D Wireframing techniques. We study two design processes executed by novice students and advanced students in mechanical engineering. The two design processes are freeform and a design process inspired in TRIZ principles.

Students groups were selected in such a way that we can observe differences between the cognitive, interpretative and creative processes. Novice students are from the first semester of mechanical engineering (sophomore). Advanced students are from the last semesters of mechanical engineering (senior). It is expected that both groups are very different in the cognitive, interpretative and creative processes.

The general statistics of the universe of students studied were the following. There were 95 students from 4 groups in total (2 novice and 2 advanced), 57 novice students and 38 advanced students. From the general information got from the students, 95% and 84% of the novice and advanced students respectively were man. 86% and 39% of novice and advanced students

respectively were between 15 to 20 years old; 14% and 42% respectively were between 21 and 25 years old; 19% of the advanced students were more than 25 years old. 70% and 58% of novice and advanced students respectively do not have industrial experience.

5.1 First experiment

Work done by hand can achieve a high level of quality. There are a lot of examples from the art craft domain. Automate such manufacturing processes is a highly complex task since it demands mechatronics systems with many degrees of freedom. To propose a design process for wirebending we must evaluate first the work done by hand. The first experiment was entitled “freeform construction of 3D objects by means of wire bending”. First, the students were asked to register general information. Then, a brief introduction to the rendering process was given; the main focus was to provide a background about the wire-frame version of objects. Wireframing is used as an intermediate step to obtain rendering. Wireframing is an implemented function of several CAD/CAE platforms. Wireframing form depends on the finite element chosen (e.g. circle, square, triangle, etc.). Wireframing can be also seen as a kind of mesh. Third, students were asked to make three sketches where they will present the mesh of a cup (divergent phase). The cup was chosen because it is a well known form and a common object found everywhere. They were asked to sketch the cups with three different meshes. For the convergent phase, students were asked to choose the mesh based on some criteria: originality, design, easy to build, etc. Fourth, students were provided by enough material of 16 AWG wires (same size that will be used in the expected machine). They were asked to build their prototype by hand. Figure 2 shows two pictures of this experiment. Finally a questionnaire was applied to the participant students. In the following section we will present the more important results of this experiment.



Fig. 2. Pictures from the first experiment.

5.2 Second experiment

Once the formative process was known by the students and they provided their qualitative evaluation to such process. In the second experiment we proposed a methodology that students followed also by hand. The objective of this experiment was to compare qualitatively the freeform style previously experimented with our methodology to manufacture the 3D object by wire bending. Therefore, the second experiment was entitled “MDSU-based construction of 3D objects by means of wire bending”. The MDSU is our proposed methodology. It stands for Mesh, Unfolding (*Desdoblado*), Separation and Union

(MUSU in English). The MDSU approach proposed here reduces the degree of freedom necessary in mechatronic systems to automate the process. These four sub-processes belong to TRIZ principles. Mesh and Separation match with the TRIZ Segmentation principle which consists on divide the object in independent parts. Recall that mesh is compared by finite element where each element is independent. Unfolding phase match with the TRIZ Flexible Shells and Thin Films principle which suggest to use thin and flexible surfaces instead of three-dimensional structures. A simplification of this principle to wireframing takes in consideration only the vertices. The last sub-process of our methodology (Union) match again with the TRIZ Segmentation principle; which consist on facilitating the assembly of the product. It is worth to say that none of the students know the TRIZ methodology and the only possibility to evaluate it is by means of proposing them a methodology inspired on it. Our proposed MDSU methodology is intended to reduce the complexity of making a 3D physical modelling machine and instead manufacturing a 2D physical model and then fold and union it to build a 3D object. We think that this formative manufacturing process is less complex. Furthermore, we are proposing this sequence of applications on TRIZ principles but other sequences might also be explored.

Students were asked to make sketches of the process. They were asked to make at least four alternatives (divergent phase). Figure 3 (right) shows a student work of this experiment. Once they finished the sketches, students were asked to choose on option (convergent phase) and executed accordingly (left figures). They made the experiment with plastic cups commercially available. The tools used by the students were mainly scissors. Finally a questionnaire was applied to the participant students. In the following section we will present the more important results of this experiment.



Fig. 3. Pictures from the second experiment.

5.3 Third experiment

The third experiment has the objective to find the best design to the machine automating the MDSU methodology. This experiment was entitled "Automated machine for rapid 3D

physical modelling based on wire bending". Previous experiments were executed with the objective that students have well knowledge of the methodology and its complexity. This experiment was divided in two parts. The first parts consisted in a questionnaire that asked the students about the possibility to automate the MDSU methodology. The technical questions were oriented to design requirements. The second part of this experiment consisted on asking the students a design proposal for the machine. The proposals were done by teams of students. After a self-selected team formation the number of novice teams was 12 and the number of advanced teams was 15. Novice teams were composed by 4 or 5 members. Advanced teams were composed by 3 members. Teams were asked to propose two alternatives, choose and modelling one. Teams had one month to elaborate their proposal in a CAD platform. The experiment was concluded with the presentation of the proposals. Figure 4 shows two proposals from the novice teams and Figure 5 shows two proposals from the advanced teams.

All experiments were executed during the semester August-December 2010. Post-analysis was executed during the first months of 2011.

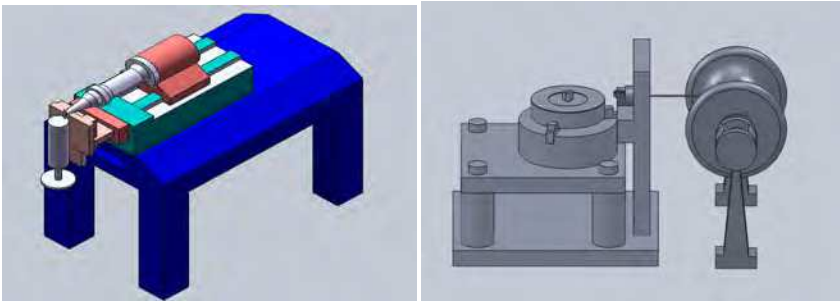

Fig. 4. Examples of proposals from novice teams.

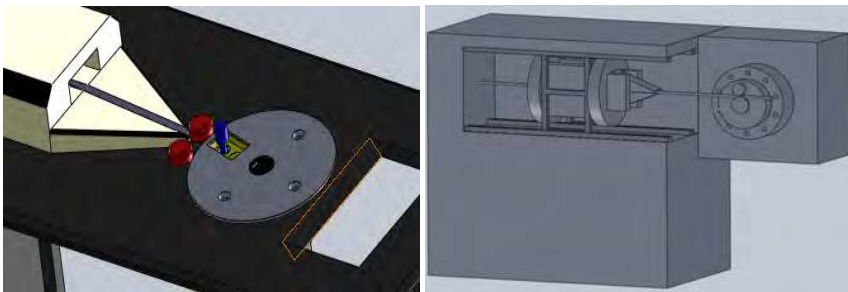

Fig. 5. Examples of proposals from advanced teams.

5.4 The proposed design methodology for rapid 3D wireframing techniques

As explained in Sections 4 and 5, the proposed process to design mechatronic systems for such new rapid three-dimensional physical modelling techniques is the following: first made freeform experiments by hand, second use the proposed MDSU methodology also by hand (the objective of this methodology is to reduce the complexity of the formative

manufacturing process for the new rapid three-dimensional physical modelling technique), finally the designer is able to propose a machine (design requirements) for new rapid 3D wireframing techniques.

6. Analysis

6.1 Freeform construction of 3D objects by means of wire bending

The first question was about the thinking process followed by students to manufacture the cup by wire bending. The answer options were: top-base-walls, base-top-walls, base-wall-top, meshed walls-top-base, meshed walls-base-top, 2D meshed, cut sections and union and other. 33% and 30% of the novice and advanced students respectively chosen the top-base-walls thinking process. 28% and 35% of the novice and advanced students respectively chosen the base-x-y thinking process, where “x” and “y” are base or walls. 30% and 26% of novice and advanced students respectively chosen the meshed walls-w-z thinking process, where “w” and “z” are base or top. In general, the common way to think about manufacturing a cup with wire is to build in the following sequence top-base-walls. There are no significant difference between novice and advanced students. If we analyze the statistics deeper, advanced students start with the base more than with the top (35% versus 33%) but the difference is not significant. In general terms three thinking approaches are found with similar statistics: top, base and meshed walls. Something interesting is that 2D mesh and union as well as sections cut and unions were the less considered thinking approaches. This is interesting to us because the MDSU approach is more based on mesh and unions. By investigating deeper, this was the result of the instruction that students must build the cup in a continuous way without any cut. But according to our observations a little quantity of students did the job without any cuts.

To the question about the most used basic figure. 36% of the novice students have chosen the circle while 26% of the advanced students have chosen the triangle. Our interpretation is that novice students were inspired by the form of the cup while advanced students were influenced by the knowledge provided in the finite element course they are taking. Another important percentage was assigned to the mix use of basic forms.

Questions related to the criteria that students have used to choose the proposal to be built by hand were applied (divergent phase). The criteria were: design, structural strength, easy to build and material optimization. 30% and 23% of novice and advanced students respectively considered in 100% the design criteria to select their proposals. With respect to the structural support criteria, 36% and 28% of novice and advanced students respectively took into account in 100% this to select their proposals. 17% and 23% of novice and advanced students respectively considered in 100% the easy to build criteria to select their proposals. Finally, 16% and 21% of novice and advanced students consider in 100% the material optimization criteria to select their proposals. From these results, we conclude that structural support was the most important criteria to select their proposals and therefore the most important design requirement for both groups. The novice students considered this criteria more important than advanced students.

To the question about the time spent to manufacture the proposal, novice students spent between 30 to 75 minutes to manufacture their proposal while advanced students spent between 15 to 45 minutes. The results are as expected, advanced students have more manual skills than novice students. It was observed that some students developed a support to manufacture their proposals. Because of that we asked the students if they consider that is

necessary some kind of support to manufacture their proposals. 86% and 70% of novice and advanced students respectively think they do not need a kind of support to manufacture their proposals. Our interpretation is that advanced students have more skills and know more tools to develop their proposal and therefore they think in less percentage that they do not need a support.

Because in the first experiment the students manufacture their proposals by hand, a question related to the use of special tools was applied. The results shown that 11% of the novice students and 100% of the advanced students think they need a tool to manufacture their proposals. Furthermore, students were asked about the type of manual tool they need. The results shown that 91% and 94% of the novice and advanced students consider they need tweezers. Other manual tools selected by the students where molds, folding machine, scissors, imagination and none.

An important question about cognition was applied to the students. The question was about generation of ideas about how to improve the formative manufacturing process. 40% and 35% of novice and advanced students respectively feel at 100% that they generate ideas during the experiment. These results show to us that hand manufacturing help to generate ideas (increase creativity).

Recognizing that the final model the students made was a wire-frame model of a 3D object. Students were asked about post-processes needed to finish a 3D object (mock-up). Among the post-processes students proposed are: finishing, structural support, covers, soldering unions, painting, etc. Of the most important for both students were finishing, fixing the support and covering the walls.

One final question about the complexity of the experiment was applied to the students. 8% and 9% of the novice and advanced students considered at 100% the experiment complex. Almost 80% of their appreciation falls between 50% and 75% of level of complexity with a more percentage in the 75%. We conclude that in general students of both levels considered the experiment with some complexity.

6.2 MDSU-based construction of 3D objects by means of wire bending

A set of questions were applied after the students executed the second experiment. There were almost the same questions that in the first experiment. These set of questions will help to us detect the impact of our methodology which is inspired in TRIZ principles. In this section first we will present the questions that are unique to this experiment then in the following section we will present the comparison between the first and second experiments.

The MDSU methodology was executed twice. With respect to the question about the unfolding the options for both executions are: separate the base and sectioned walls, keep the base with sectioned walls, base and walls sectioned, keep some section of the based together to the walls and other. In the first intend, 42% of the novice students chosen the second option while 42% of the advanced students chosen the first option. In the second intend both types of students exchange their choices. In general the first two options were chosen by both types of students. We think that students did not explore other potential possibilities because time restrictions on the experiments. We also asked to the students if the unfolding stage was confused and why. The results showed to us that almost half of the students consider confuse the unfolding stage. The most important reason why they consider that the unfolding is confused is that was difficult to imagine the unfolding.

Another question was related to the complexity of the union sub-process in the MDSU methodology. 29% and 42% of novice and advanced students respectively considered the union sub-process as complex.

In a later section we will compare the first experiment with the second experiment in this parameter. We will also present a comparison of some criteria students took into consideration to select their proposals. Here we present some of the criteria that are not comparable and belong only to the MDSU methodology. Students were asked if once the object was unfolded sectioning was easy. 32% of both type of students considered at 100% that the model was easy to section. Students were asked about other criteria considered to decide their proposals. But they are less relevant for the objective of this study and therefore we will not present them here. Students were also asked about difficulties on the MDSU and related processes but the results will be presented in the following section.

6.3 Comparison between the first and the second experiment

The first compared question is about the geometrical form used in the meshing sub-process (finite element). According to our statistics, most of the geometrical forms used were mix. Both types of students mix more the geometrical figures during the second experiment. In novice students increased 20% while in the advanced students the increase was about 32%. Therefore, there is some evidence that the MDSU methodology help to increase the variability of geometrical forms used in the meshing sub-process. The use of mix forms was superior in the advanced students that in the novice students. The basic form with significant more use after the mix was the circle. This form was reduced about 24% in novice students and 15% in advanced students from the first to the second experiment. The use of triangle was not significantly changed as well as the square. Another important change was perceived in the spiral form; it was reduced about 7% in novice and advanced students. Other forms used where polygon. As we can appreciate the MDSU methodology impact positively the variation of forms more in the advanced students that in the novice. This may be due to the freedom feeling experienced by the advanced students. The triangle is the most suggested form used in finite element theory and according to our statistics it was not changed significantly. This is a positive result because the MDSU does not affect the percentage of use in this form.

When comparing the design criteria for choosing the proposals. The MDSU methodology impacts positively advanced students. For such group of students and at 100%, the criteria is increased by 8% while for novice students the increase is about 7% On the other side, when comparing the easy to build criteria a significant increase is perceived in novice students from 50% to 75%, the increase at 75% is about 29%. At 100%, both groups of students showed an increase when using the MDSU methodology. 15% in novice students and 9% in advanced students. With respect to material optimization criteria, the behavior is of the same kind but at different percentages. The increase at 100% was about 6% in novice students while 8% in advanced students.

The experimentation time had a positive impact also. The more significant increase was shown between 0 and 15 minutes for novice students. By using the MDSU methodology they increase 14% their experiment time. The timeframe between 15 and 30 minutes have had also a positive impact by decreasing less than 10% percentage. Timeframes above 30 minutes had a reduction. These results shown that the MDSU methodology reduces the timeframe spent in the experiment.

Two final important questions were compared. The first was about the complexity of the experiment. At 100%, both group of students considered that the MDSU methodology is less complex than the freeform methodology. Advanced students feel that MDSU methodology reduces the complexity more than the novice students do. The other important question is more related to cognitive processes, specially the creativity. At 100% and 75% (more at 75%) feel that the MDSU methodology reduces the generation of ideas to improve the process.

6.4 Automated machine for rapid 3D physical modeling based on wire bending

The first question of this experiment was about the credibility of both groups of students about the feasibility of automating the MDSU process. 96% and 97% of the novice and advanced students respectively thought that the MDSU process can be automated. Students that do not believe in the automation of the MDSU process justified their answer by stating that such process is not really necessary. We believe that such answers were because they are young and do not foresee potentialities in automating such methodology. From the question that the MDSU process will need a software, 82% and 97% of the novice and advanced students respectively believe that the MDSU process will need a software. Our interpretation of the difference in results is that advanced students have used more software than novice students and therefore they do not see the MDSU process without software. On the contrary novice students have not used so much software as advanced students.

The next series of questions were about the criteria to be considered in the design of a machine that automate the MDSU process. The list of criteria is: design, functionality, manufacturability, execution times, precision, size, feasibility, sustainability, security, easy machine user interaction. For the novice students, the functionality criteria was the most important among all the criteria, followed by manufacturability, execution time, security, then by the design and machine user interaction. For the advanced students the security criteria was the most important followed by the machine user interaction and then by the functionality criteria. Another series of questions were about the criteria students will consider to select if the machine already existed. Novice students selected the precision as the most important factor followed by material optimization and mesh structure. Advanced students selected the precision as well as the most important factor followed by material optimization and mesh structure. The size of the machine was the less important factor.

Another important question was about the students' opinion if the machine will be dedicated to prototypes or final products. 90% of both types of students believe that the machine will serve for prototypes. The last series of questions we asked to the students were about their appreciation of the MDSU-based machine on: reducing complexity, reducing creativity, reducing manufacturing time, and improves work conditions. 49% and 47% of novice and advanced students respectively believe that the MDSU-based machine reduce the complexity of manufacturing 3D Wireframing objects. 49% and 24% of novice and advanced students respectively believe at 100% that the MDSU-based machine will reduce the creativity. This criteria has a more uniform distribution from the 25% to 100%. 75% and 66% of novice and advanced students respectively believe at 100% that the MDSU-based machine will reduce the manufacturing time. Among the set of criteria evaluated in this last series of questions this is with the more believability. The last criterion in this series is about the improvement of work conditions. 60% and 66% of novice and advanced students respectively believe at 100% that the MDSU-based machine will improve the work conditions.

The last series of analysis executed in this experiment was about the students' proposals. In section 5.3 we have provided some examples of MDSU-based proposals. Students were asked to make their proposals without design restrictions; except that all must meet the MDSU methodology. Novice student proposals were more oriented to the mesh sub-process while advanced student proposals met well the MDSU process. A comparison among the proposals was executed taking into account the following sub-processes: meshing, folding, sectioning, cut, union, wire size, machine size, continuous feeding, straighten system, diversity of forms capability, folding ranges. It was noticed that cut and wire size was met by all the proposals in both types of students. 92% and 100% of novice and advanced student proposals respectively are machines of considerable size. 83% and 93% of novice and advanced student proposals respectively consider continuous wire feeding. 58% and 53% of novice and advanced student proposals respectively met with the meshing requirement. 67% and 87% of novice and advanced student proposals respectively met the folding requirement. 50% and 73% of novice and advanced student proposals respectively met the sectioning requirement. In general advanced student proposals met the MDSU requirements better than the novice student proposals; except the meshing requirement but not for more than 5% of difference.

7. A first prototype

The current prototype was conceived in a multidisciplinary way almost following the concurrent engineering approach. Three different specialties were participating: industrial design, mechanical engineering and electronic engineering. A professor from each specialty and a Master of Science student from each discipline participated. We had meetings every three weeks. During the meetings the final mechanical design was decided. Once the mechanical design was decided, the electronic design starts to automate the machine. Our first prototype was developed during these meetings. Figure 6a shows the first prototype we developed. There were no design process followed for the first prototype. After the first proposal we carried out some simulations in Rhino™ to detect possible problems. We found some problems that were corrected in the second prototype shown in Figure 6b. The prototype shown in Figure 6a can only make wire bends from $\pm 90^\circ$. Figure 7 shows a picture of the real prototype as shown in Figure 6b. Some first tests were executed with basic 2D figures. Figure 8 shows some basic geometrical forms done with our first prototype. The

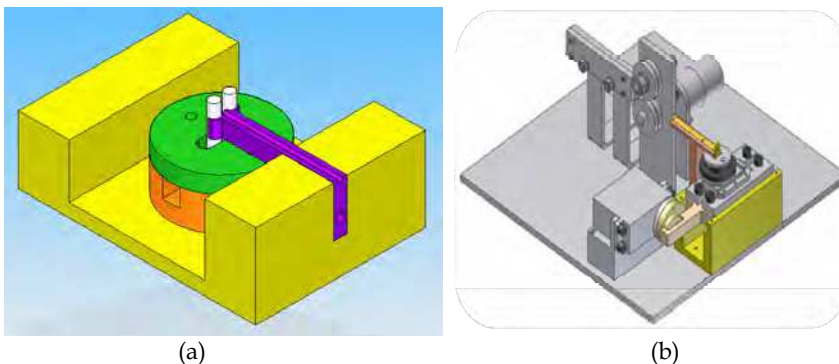

Fig. 6. First prototypes.

reader can appreciate that many changes must to be done before our first MDSU-based prototype machine will be achieve. With the design process we propose here and its results we will propose a new machine that meets the MDSU requirements. Due to intellectual property rights we cannot show more details of our first prototypes.

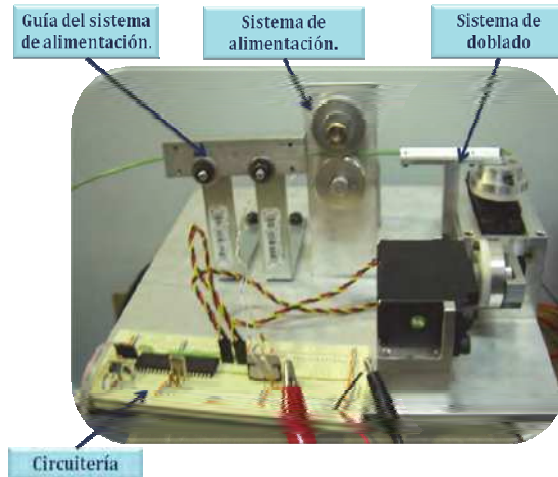

Fig. 7. Picture of the first prototype.

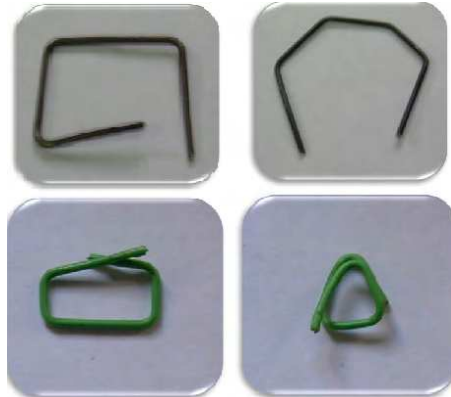

Fig. 8. Basic geometrical forms manufactured with our first prototype.

8. Conclusions and future work

In this chapter we have proposed a methodology inspired in TRIZ principles to design mechatronic systems for a new rapid 3D physical modeling technique based on formative manufacturing processes. This chapter has several contributions that will be outlined in the following. First, it presents a match between the most important engineering design frameworks: engineering design process, product lifecycle management and project

management. It also adds an experienced course published previously (Cárdenas 2009), the INNOWIZ framework and the TRIZ framework. Second, focused in the first two stage of such engineering design thinking an innovation funnel was proposed where the application of rapid prototyping techniques is outlined. Traditionally, rapid prototyping techniques are used once the concept is well defined (after detailed design) but previous research has proven to be used in early stages of design (e.g. conceptual design phase). Third, formative manufacturing processes are proposed as a new paradigm to explore the design of new rapid 3D physical modeling techniques. Fourth, a new rapid 3D physical modelling technique based on a particular case of formative manufacturing processes such as wire bending and inspired in TRIZ principles was proposed. The methodology is called MDSU (MUSU in English). Fifth, a design process for mechatronic systems of rapid 3D physical modeling techniques was proposed and consists of three stages. Making the 3D object by freeform hand, and then making the 3D object following the MDSU methodology, finally proposing new machines that automate the MDSU methodology. This new paradigm promise potential benefits in favor of sustainability issues. This design methodology does not follow the traditional engineering design path but presents an extension in the problem definition stage. Because the complexity of automating handwork operations the problem (stage one in the engineering design process) must be defined by experiencing the two first stages of the proposed design process. In other words, the first two stages of the proposed design methodology must be used in the problem definition stage of the engineering design process. The third stage consists of the rest of the engineering design process from researching the problem. Now, according to our experiments, the MDSU methodology increases the use a mix of geometrical forms in both novice and advanced designers. In general, the design criteria in both types of designers are increased if the MDSU methodology is used. Another positive impact of the MDSU methodology was the execution time. Execution time was shown to improve. It is expected that machines using this methodology will perform better in terms of time. The MDSU design methodology reduces the complexity to manufacture rapid 3D physical models, specifically rapid 3D wireframing objects. We have some evidence that, MDSU-based machines will reduce the time and complexity to manufacture 3D wireframing models but also will reduce the capacity to generate ideas. On the contrary, it will promise to improve work conditions. Finally, advanced student proposals met better the MDSU design requirements that novice student proposals except for the meshing sub-process. Finally, we provide advancements of our first prototype machine which by now process only basic two-dimensional figures.

As a future work, we are planning to finish the first prototype that follows the MDSU methodology. It will surely comprise hardware and software advancements with respect to the Figures 6b and 7 shown previously. We also plan to continue the evaluation of the same parameters used to conclude in this chapter and a deeper analysis of the current results. Finally, formative manufacturing processes are a wide potential area that has been less exploited and the different types of material might open new potential possibilities. We will explore the application of our MDSU process to new rapid 3D physical modeling techniques not only based on one-dimensional materials but two- and three-dimensional.

9. Acknowledgments

Authors would like to thank the support of CONACYT, the Mechatronics department at Tecnológico de Monterrey - Campus Querétaro, and the Master in Manufacturing Systems

at the same Institution. This work has been supported by the Distributed and Adaptive Systems Lab for Learning Technologies, DASL4LTD (C-QRO-17/07) and by the Innovation in Design and Manufacturing Research chair, both from Tecnológico de Monterrey - Campus Querétaro.

10. References

- Bruno, F., Giampf, F., Muzzupappa, M., Rizzuti, S. (2003). A Methodology to Support Designer Creativity During the Conceptual Design Phase of Industrial Products. Proceedings of the 14th International Conference on Engineering Design ICED03.
- Buchal, R.O. (2002). Sketching and Computer-Aided Conceptual Design. The 7th International Conference on Computer Supported Cooperative Work in Design, 2002.
- Buswell, R.A. (2007). Applying future industrialized processes to construction. IN: Walker. N. (ed.). Proceedings of CIB World Building Congress 'Construction for Development' 14-17 May 2007, Cape Town, South Africa.
- Buxton, B.(2007). Sketching user experiences - Getting the Design Right and the Right Design. Springer (1st Edition).
- Cárdenas, C. (2009). Social Design in Multidisciplinary Engineering Design Courses. 39th IEEE/ASEE Frontiers in Education Conference, San Antonio Texas, USA, October 18-21.
- Cárdenas, C., (2011). A Multidisciplinary Approach to Teach the Design of Socially Relevant Computing Systems for Social Change. International Journal of Engineerinf Education, Vol 27. Issue 1, pp. 3-13.
- Cha, J., Jardim-Gonclaves, R., & Steiger-Garcia, A. (2003). Concurrent Engineering. Taylor & Francis (1st Edition).
- Chua, C. K., Leong, K. F. & Lim, C. S. (2010). Rapid Prototyping: Principles and Applications. World Scientific Publishing Company. (3 edition).
- Crawley, E., Malmqvist, J., Ostlund, S., Brodeur, D. (2010). Rethinking Engineering Education: The CDIO Approach. Springer (1st Edition).
- Demaine, E.D. & O'Rourke, J., (2007). Geometric Folding Algorithms: Linkages, Origami, Polyhedra. Cambridge University Press, July 2007. xii+472 pages. ISBN 978-0-521-85757-4.
- Dym, C.L., Agogino, A.M., Eris, O., Frey, D.D., Leifer, L.J., (2006). Engineering Design Thinking, Teaching, and Learning. IEEE Engineering Management Review. Vol. 34, Issue 1.
- Gibson, I., Rosen, D.W. & Stucker, B. (2009). Additive Manufacturing Technologies: Rapid Prototyping to Direct Digital Manufacturing. Springer (1st Edition).
- Hopkinson, N., Hague, R., & Dickens, P. (2006). Rapid Manufacturing: An Industrial Revolution for the Digital Age. Wiley. (January 16, 2006).
- Jenkins, D.L. & Martin, R.R. (1993). Importance of free-hand sketching in conceptual design: Automatic sketch input. ASME DES ENG DIV PUBL DE., ASME, NEW YORK, NY (USA), 1993, vol. 53, pp. 115-128.
- Kamrani, A. K., & Nasr, E.A. (2010). Computer based design and manufacturing. Springer (1st Ed.).
- Kamrani, A. K., & Nasr, E.A. (2010). Engineering Design and Rapid Prototyping. Springer (1st Ed.).

- Kiritsis, D. (2011). Closed-loop PLM for intelligent products in the era of the Internet of things. *Computer Aided Design*. Vol. 43, Issue 5 May 2011, pp 479-501.
- Kupka, L. (2010). Physical modelling aids feeder design and assessment. *Glass International*. Vol. 33, (2010), pp. 31-35.
- Lessard, C., (2007). *Project Management for Engineering Design*. Morgan and Claypool Publishers (1st Edition).
- Orloff, M.A. (2010). *Inventive Thinking through TRIZ: A Practical Guide*. Springer (2nd Ed.).
- Pahl, G., Beitz, W., Feldhusen, J., & Grote, K.H. (2007). *Engineering Design: A Systematic Approach*. Springer (3rd. Edition).
- Plattner, H., Meinel, C., & Leifer, L. (2010). *Design Thinking: Understand - Improve - Apply*. Springer (1st Edition).
- Saaksvuori, A., & Immonen, A. (2010). *Product Lifecycle Management*. Springer (3rd Ed.).
- Schrage M. (1993). The culture(s) of prototyping, *DesignManagement Journal*, 1993, 4 (1) : 55-65. In Broek Johan J., Sleijffers, Wouter, Horvath, Imre, 'Using Physical Models in Design' Dept. of Design engineering, Delft Univ. of Technology.
- Simondetti, A. (1998). Rapid Prototyping Based Design: Creation of a Prototype Environment to Explore Three Dimensional Conceptual Design. *Cyber-Real Design Bialystock (Poland)*, 23-25 April 1998, pp. 189-203.
- Smith, P.G. & Reinertsen, D.G. (1998). *Developing Products in Half the Time*, John Wiley and Sons (2nd Edition), New York, 1998.
- Suh, S.H., Kang, S.K., Chung, D.H. & Stroud, I. (2010). *Theory and Design of CNC Systems*. Springer (1st Edition).
- Zailani, S., Rajagopal, P., Jauhar, J. & Wahid, N.A. (2007). New product development benchmarking to enhance operation competitiveness. *International Journal of Services and Operations Management*. Vol. 3, no. 1, (2007), pp. 23-40.

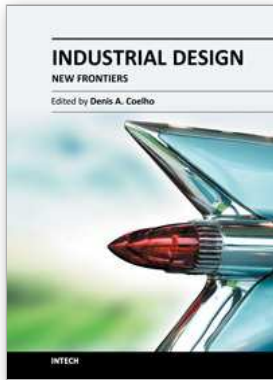

Industrial Design - New Frontiers

Edited by Prof. Denis Coelho

ISBN 978-953-307-622-5

Hard cover, 190 pages

Publisher InTech

Published online 09, November, 2011

Published in print edition November, 2011

A new breed of modern designers is on the way. These non-traditional industrial designers work across disciplines, understand human beings, as well as business and technology thus bridging the gap between customer needs and technological advancement of tomorrow. This book uncovers prospective designer techniques and methods of a new age of industrial design, whose practitioners strive to construct simple and yet complex products of the future. The novel frontiers of a new era of industrial design are exposed, in what concerns the design process, in illustrating the use of new technologies in design and in terms of the advancement of culturally inspired design. The diverse perspectives taken by the authors of this book ensure stimulating reading and will assist readers in leaping forward in their own practice of industrial design, and in preparing new research that is relevant and aligned with the current challenges of this fascinating field.

How to reference

In order to correctly reference this scholarly work, feel free to copy and paste the following:

César Cárdenas, Yuliana Rivera, Ricardo Sosa and Oscar Olvera (2011). TRIZ-Based Design of Rapid 3D Modelling Techniques with Formative Manufacturing Processes, *Industrial Design - New Frontiers*, Prof. Denis Coelho (Ed.), ISBN: 978-953-307-622-5, InTech, Available from: <http://www.intechopen.com/books/industrial-design-new-frontiers/triz-based-design-of-rapid-3d-modelling-techniques-with-formative-manufacturing-processes>

INTECH
open science | open minds

InTech Europe

University Campus STeP Ri
Slavka Krautzeka 83/A
51000 Rijeka, Croatia
Phone: +385 (51) 770 447
Fax: +385 (51) 686 166
www.intechopen.com

InTech China

Unit 405, Office Block, Hotel Equatorial Shanghai
No.65, Yan An Road (West), Shanghai, 200040, China
中国上海市延安西路65号上海国际贵都大饭店办公楼405单元
Phone: +86-21-62489820
Fax: +86-21-62489821